

## Overview and Identification

The BAPI Differential Pressure Switch is ideal for air filter monitoring, static pressure proving, airflow proving or auxiliary fan actuation. Because of its UL 353 Limit Control Listing, the BAPI Switch can be used in safety circuits to protect heating appliances, heating systems, processing systems and HVAC/R systems.

The setpoint is field adjustable from 0.1" to 35" WC, and the unit can measure positive pressure, vacuum or true differential pressure. The seven pressure ranges are field selectable by changing a color-coded spring. The spring for the range that you order is preinstalled, and the other six springs are shipped with the unit so that you can change ranges in the field if you choose.

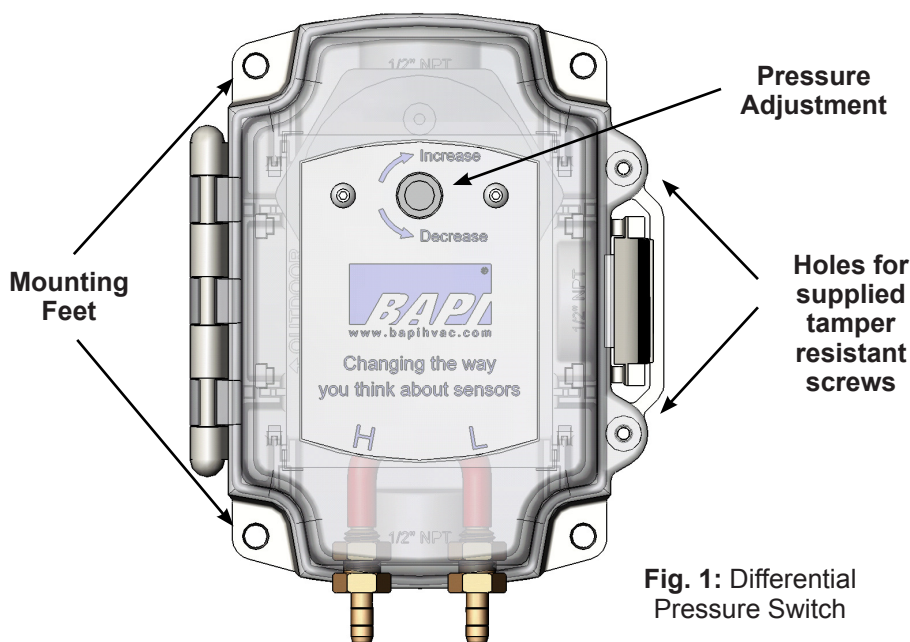

**Fig. 1:** Differential Pressure Switch

## Specifications

### Pressure Range:

ZPS-SW1: 0.12" to 0.52" W.C. (30 Pa to 130 Pa)  
ZPS-SW2: 0.40" to 1.40" W.C. (100 Pa to 350 Pa)  
ZPS-SW3: 1.20" to 2.40" W.C. (300 Pa to 600 Pa)  
ZPS-SW4: 2.40" to 6.42" W.C. (600 Pa to 1,600 Pa)  
ZPS-SW5: 5.22" to 12.84" W.C. (1,300 Pa to 3,200 Pa)  
ZPS-SW6: 11.64" to 23.68" W.C. (2,900 Pa to 5,900 Pa)  
ZPS-SW7: 21.68" to 35.32" W.C. (5,400 Pa to 8,800 Pa)

**Pressure Ports:** 1/4" brass

**Proof Pressure:** 100" W.C. (3.6 PSI, 24,900 Pa)

**Switch Type:** SPDT (Silver Contacts)

### Contact Rating: (UL 353)

28 VA pilot duty, 24 VAC  
1/10 hp, 120-277 VAC  
125 VA pilot duty, 125 VAC  
2.5 A inductive, 125 VAC  
5 A resistive, 125 VAC

**Contact material:** Silver

**Operating Temperature:** -40 to 185°F (-40 to 85°C)

**Operating Humidity:** 5 to 95% RH non-condensing

**Measurement Media:** Air or Combustion Gases

**Warranty:** 5 Years

### Mounting

1. Hold the unit vertical in its mounting location and mark the holes in the mounting feet or use the actual size mounting template shown in Fig. 3 below. (Note: If unit is mounted outside, it must be oriented horizontal with the latch down and the ports to the left.)
2. Using # 10 screws attach the box to the mounting surface.

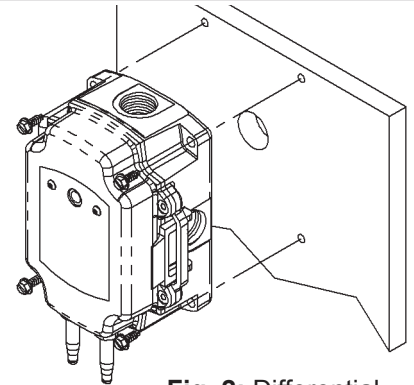

**Fig. 2:** Differential Pressure Switch Mounting

(Note: If unit is mounted outside, it must be oriented horizontal with the latch down and the ports to the left.)

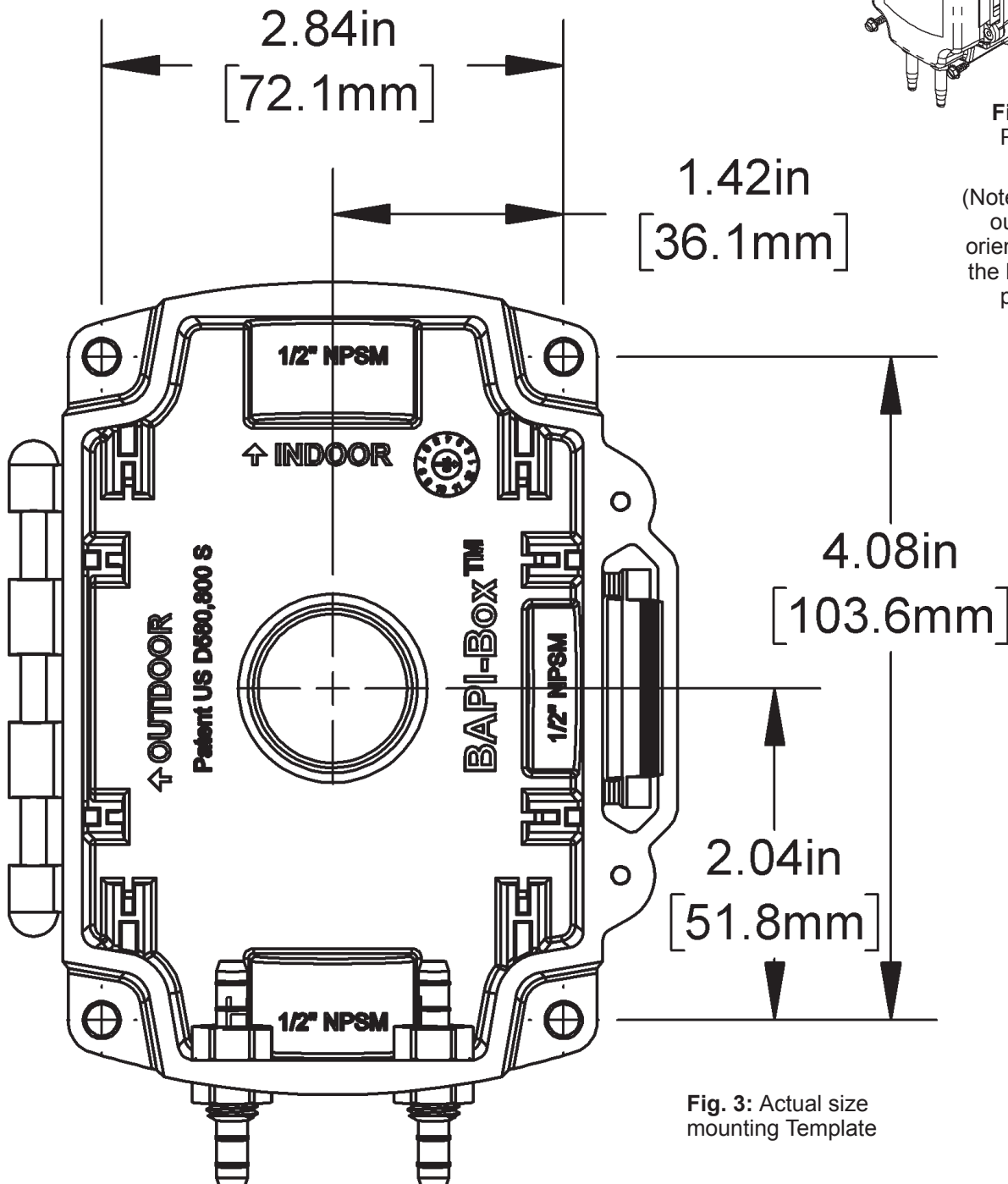
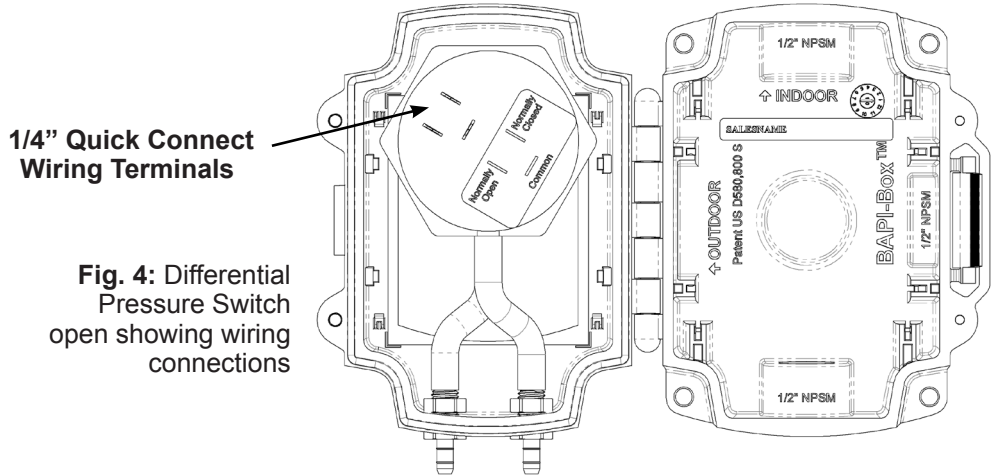

**Fig. 3:** Actual size mounting Template

Specifications subject to change without notice.

## Termination

1. Attach wire to the wiring terminals using supplied crimp terminals, close the cover and push on the cover until it latches closed.
2. Secure cover with tamper resistant screws if desired.



**Fig. 4:** Differential Pressure Switch open showing wiring connections

## Pressure Adjustment

The Differential Pressure Switch comes adjusted as shown in the table below.

Model	Spring Color	Setpoint range	Setpoint change per turn	Initial factory setpoint $\pm 10\%$
ZPS-SW1	Brown	0.12" to 0.52" W.C. (30 Pa to 130 Pa)	0.05" W.C. (12 Pa)	0.31" W.C. (77 Pa)
ZPS-SW2	None	0.40" to 1.40" W.C. (100 Pa to 350 Pa)	0.11" W.C. (28 Pa)	0.90" W.C. (225 Pa)
ZPS-SW3	Orange	1.20" to 2.40" W.C. (300 Pa to 600 Pa)	0.15" W.C. (37 Pa)	1.88" W.C. (470 Pa)
ZPS-SW4	Blue	2.40" to 6.42" W.C. (600 Pa to 1,600 Pa)	0.45" W.C. (112 Pa)	4.38" W.C. (1,090 Pa)
ZPS-SW5	Red	5.22" to 12.84" W.C. (1,300 Pa to 3,200 Pa)	0.85" W.C. (211 Pa)	9.03" W.C. (2,250 Pa)
ZPS-SW6	Purple	11.64" to 23.68" W.C. (2,900 Pa to 5,900 Pa)	1.34" W.C. (333 Pa)	17.66" W.C. (4,400 Pa)
ZPS-SW7	Green	21.68" to 35.32" W.C. (5,400 Pa to 8,800 Pa)	1.52" W.C. (378 Pa)	28.50" W.C. (7,100 Pa)

Insert an SQ1 square bit (0.110 inches, 2.8mm) into the pressure adjustment screw and turn clockwise to increase the pressure at which the switch closes. Turn counterclockwise to decrease the pressure at which the switch closes.

### CHANGING PRESSURE RANGES

Change pressure ranges by replacing the spring behind the pressure adjustment screw. Turn the pressure adjustment counterclockwise until it is loose from the switch body; be careful not to drop the screw. Using needle nose pliers remove the pressure regulation spring. Place the spring into the empty plastic bag inside the switch case.

Find the bag with the spring for the pressure range you need. Remove the spring from the bag, place the spring into the hole behind the pressure adjustment screw and put all the plastic bags with springs and the empty bag into the switch case.

Place an Ohmmeter or indicating lamp across the common and normally closed switch contacts, the switch should indicate open (High resistance or no light.). Place the pressure adjusting screw into its hole and slowly turn the screw clockwise. Somewhere between three and seven turns the switch will close (low resistance or light turns on), this is the low end of the switches working pressure. From this point, nine more turns will be the highest working pressure for that spring. If you turn the pressure adjusting screw more than nine turns, it will be locked into position and no amount of pressure will cause it to switch.

## Pressure Adjustment continued...

### PROPER ADJUSTMENT PROCEDURES

Make all adjustments slowly. There is a restriction orifice built into the switch that acts as a pressure snubber. The snubber filters out transient pressure spikes that would ordinarily cause nuisance pressure switch actuations. The snubber slows down the air entering the switch's pressure chamber. At low differential pressures it can take a couple of seconds for the pressure switch chambers to fill with air.

First set the spring to the bottom of its range as described in changing pressure ranges above. Turn the adjustment screw clockwise two turns and apply the pressure that you wish the pressure switch to switch at. Follow either A or B below.

- A. If the pressure switch does not switch, release the pressure and turn the adjustment counterclockwise about  $\frac{1}{4}$  turn. Repeat as necessary until the pressure switch switches at the pressure you desire.
- B. If the pressure switch switches, release the pressure and turn the adjustment clockwise about  $\frac{1}{4}$  turn. Repeat as necessary until the pressure switch switches at the pressure you desire.

Always release the pressure between trials. If you do not release the pressure while you are adjusting the screw the switch contacts "stick" making adjustment impossible.

## Applications

### AIR FILTER MONITORING

The static pressure on each side of a filter is compared and the output contacts close when the pressure across the filter exceeds a predetermined value. Ideally a BAPI Static Pressure Probe (ZPS-ACC07) is placed one duct diameter upstream of the filter and another Static Pressure Probe one duct diameter downstream of the filter. Connect the upstream static pressure probe to the high port on the Differential Pressure Switch and the downstream probe to the low port on the Differential Pressure Switch.

To set the pressure trip point, remove the tubing from the Differential Pressure Switch. Connect a manometer and a pressure source to the high pressure port on the Differential Pressure Switch. Use the manometer to measure the pressure. Set the pressure as described in the Proper Adjustment Procedures section above. Reconnect tubing when finished.

An alternative way to adjust the pressure setpoint is;

1. Place a new, clean filter into the duct.
2. Turn on the fan.
3. Cut a piece of cardboard approximately  $\frac{1}{2}$  the face area of the filter.
4. Place the cardboard against the filter on the upstream side.
5. Set the pressure as described in the Proper Adjustment Procedures section above.
6. Remove the cardboard.

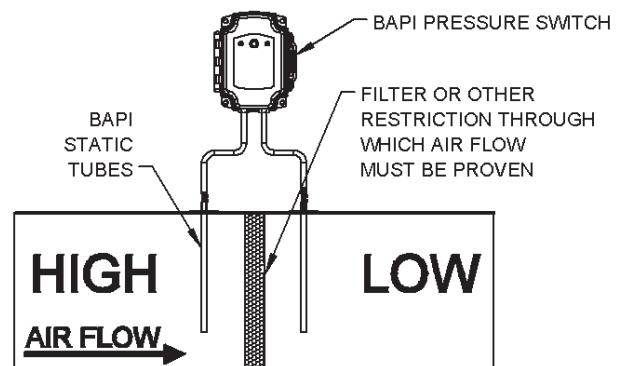

Fig. 5: Differential Pressure Switch monitoring an air filter



### Applications continued...

#### STATIC PRESSURE PROVING

Static pressure proving compares the static pressure in a monitored space to the static pressure in a reference space. The BAPI Differential Pressure Switch contacts close when the pressure exceeds the setpoint. The BAPI Differential Pressure Switch is independent of any static pressure control; it is an independent monitor and alarm if the control condition is not met.

For example, you do not wish the odors in a school chemistry laboratory to get out into the hallway. The lab is the monitored space and the hallway is the reference space. Place a Static Pressure Pickup Port (ZPS-ACC01) into the space you wish to monitor and place another Static Pressure Pickup Port into the reference space.

If you want the reference space to be higher pressure, connect the reference space to the Differential Pressure Switch high port and the monitored space to the low port.

If you want the monitored space to be higher pressure, connect the monitored space to the Differential Pressure Switch high port and the reference space to the low port.

To set the pressure trip point, remove the tubing from the BAPI Differential Pressure Switch. Connect a manometer and a pressure source to the high pressure port on the BAPI Differential Pressure Switch. Use the manometer to measure the pressure. Set the pressure as described in the Proper Adjustment Procedures section above. Don't forget to reconnect the tubing.

Another example is making sure that the static pressure in a duct is different from the static pressure in your plenum. The duct is the monitored space and the plenum is the reference space. Place a Static Pressure Probe (ZPS-ACC07) into the duct you wish to monitor and a Static Pressure Pickup Port (ZPS-ACC01) in the plenum. Connect the sensor tubes as explained above.

#### AIR FLOW PROVING

Place a Pitot Tube Assembly (ZPS-ACC11 or ZPS-ACC12) into the duct you wish to monitor. Connect the Differential Pressure Switch's high port to the total pressure probe and the low port to the static probe. Set the pressure trip point to the desired airflow.

Flow, Feet per Minute	Pressure, Inches of Water
1000	0.062
2000	0.25
3000	0.56
4000	1

To set the pressure trip point, remove the tubing from the Differential Pressure Switch. Connect a manometer and a pressure source to the high pressure port on the Differential Pressure Switch. Use the manometer to measure the pressure. Set the pressure as described in the "Proper Adjustment Procedures" section on page 4. Reconnect tubing when finished.

#### AUXILIARY FAN ACTUATION

Many appliances, clothes driers, range hoods or bathroom exhaust fans, do not have enough fan power to force sufficient air through long duct lengths. Auxiliary exhaust fans are often placed at the end of the duct to draw the exhaust air through the duct. Turning on these auxiliary fans can be difficult if the appliance does not have auxiliary fan output contacts.

You can use BAPI's Differential Pressure Switch to easily turn on the auxiliary fan. Place a Static Pressure Probe (ZPS-ACC07) in the exhaust duct and a Static Pressure Pickup Port (ZPS-ACC01) in the space with the appliance. Connect the exhaust duct to the high port on the Differential Pressure Switch. Connect the appliance space to the low port on the Differential Pressure Switch. Set the pressure trip point so that the switch contacts close whenever the appliance is turned on. Use the switch contacts to control the power to the auxiliary fan.

### Diagnostics

#### Possible Problems:

Cannot calibrate switch pressure

#### Possible Solutions:

- Make sure that the correct spring is selected
- Make sure that the high and low pressure tubes are not swapped
- Make sure that the high and low pressure tubes are connected to the proper locations and are not kinked